

International Journal of Engineering Sciences & Research Technology

(A Peer Reviewed Online Journal)
Impact Factor: 5.164



Chief Editor
Dr. J.B. Helonde

Executive Editor
Mr. Somil Mayur Shah

**INTERNATIONAL JOURNAL OF ENGINEERING SCIENCES & RESEARCH
TECHNOLOGY
SOLAR BASED EMERGENCY POWER SOLUTION FOR DISASTER
MANAGEMENT**

**Miss Pallavi G^{*1}, Miss Nishida F², Miss Rubin Sulthana Feroze B F³, Mr Ravishanker R⁴ &
Asst. Prof. Anju V Gopal⁵**

^{*1, 2, 3, 4&5}Department of electronics and communication, college of engineering perumon, India

DOI: 10.5281/zenodo.2636942

Due to natural disasters, thousands of people get displaced and are made to live in relief or refugee camps each year. Basic needs such as lighting, cooling, water etc are often unavailable and sometimes these camps may even exist for longer periods than expected. This project aims at introducing a solar based emergency power solution which can provide electrical energy to meet the energy needs in disaster prone areas and relief camps by using renewable energy tapping mechanism. The proposed model can be deployed as an emergency energy response in a self- sufficient and highly mobile fashion and can redeploy as necessary. The present work proposes the implementation of maximum power point tracking (MPPT) scheme.

KEYWORDS: MPPT, emergency power solution, renewable energy tapping mechanism, self sufficient, highly mobile

1. INTRODUCTION

Areas where natural disasters can happen anytime, disaster preparedness is a major issue. The first critically important service to be affected during natural disasters is electrical power. Because of their sustainable and stand-alone operation capabilities solar photovoltaic (PV) systems are a natural and wise solution for disaster preparedness. Solar photovoltaic systems has the potential to bring natural and reliable power to places devastated by disasters as photovoltaic power systems is an example of reliable, secure, noise free energy fuelled by the sun. In this project the solar panel is connected with MPPT module and DC-DC converter. Photovoltaic cells works at highest efficiency when it is operating at its maximum power point. A DC-DC converter is used between the solar panel and the load as an interface. The idea is to ensure the maximum performance of the setup, irrespective of the changes in physical conditions. Solar based renewable energy is more efficient with maximum power point tracking (MPPT) module as compared to the one without MPPT module.

The purpose of our project is to review the use of mobile photovoltaic system to provide electricity in the aftermath of disasters for emergency relief and to get this solar power backup in the hands of emergency response teams.

2. LITERATURE SURVEY

Since there is no access of electricity during disasters, to provide electricity, it requires propagation, transmission, distribution and management of electricity. Now a days we use diesel powered engines but it tends to be dangerous.

And the existing system takes longer time for restoration of utility electricity. So we propose our project which provides electrical energy to satisfy the basic needs and that can be deployed as an emergency response in a self-sufficient, self contained and highly mobile fashion. It supports the energy demands of a refugee or a relief camp. So the objective of our project is to provide an emergency power solution with renewable tapping mechanism.

3. DISADVANTAGES OF EXISTING EMERGENCY POWER SOLUTIONS

[http:// www.ijesrt.com](http://www.ijesrt.com) © International Journal of Engineering Sciences & Research Technology

[219]



- During natural disasters, people usually revert to diesel or gasoline powered generators which are highly unsustainable and inefficient.
- The use of diesel or gasoline powered engines can be dangerous in the hands of untrained users and can result in incidents of fire, fuel explosion, burns and these engines can be noisy.
- Difficulty in deploy and redeploy when necessary.
- Having a limited non-renewable power supply, there exists the risk of potential social instability

4. BLOCK DIAGRAM

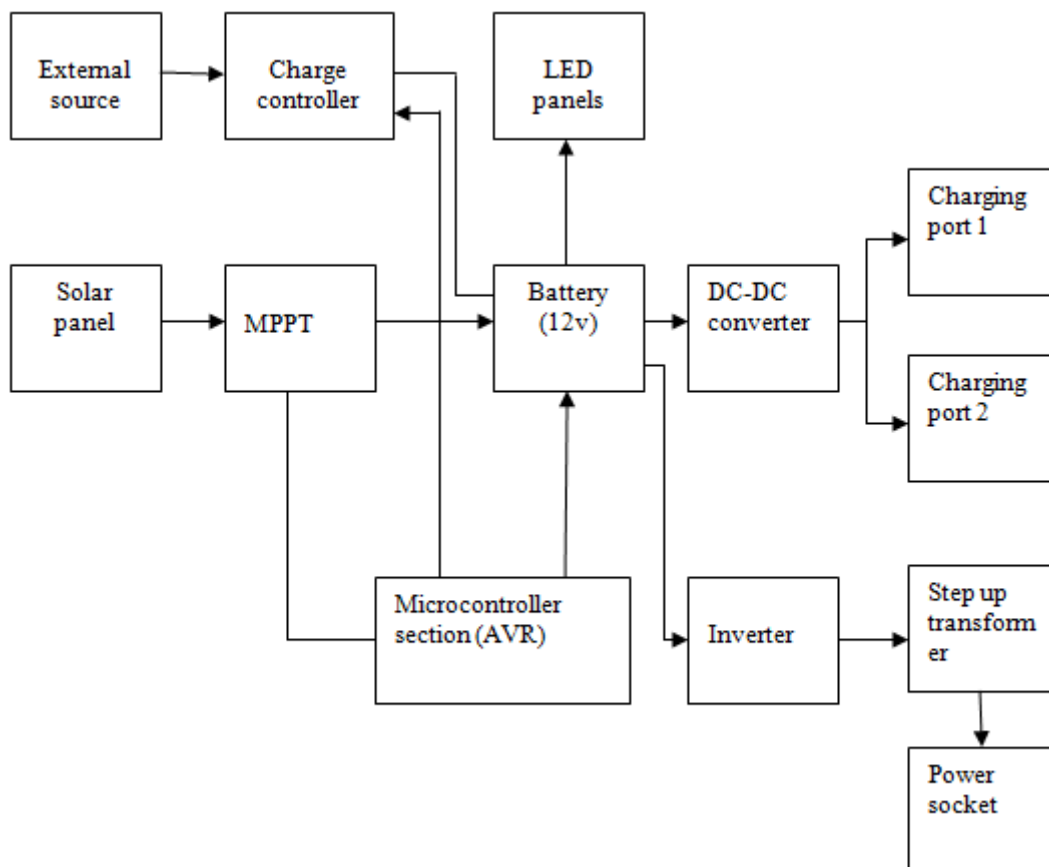

Figure 1: general block diagram

A. Working

Our basic requirements includes charging two or more mobiles and basic lighting system. Sun light is used as the major source and the sun light is absorbed by the solar panels. Here we use monocrystalline solar panels, as they are more efficient than poly crystalline solar panels. An MPPT or maximum power point tracking is an electronic DC-DC converter (buck converter) that optimizes the match between the solar array and the battery or utility grid. It consists of current sensing element, voltage sensing element and a pwm source. mppt algorithm is used to vary the pwm. The perturb and observe (P&O) method is used. The MPPT is a DC-DC converter which inputs DC from photovoltaic module and changes it to AC and convert it back to a different DC voltage and current to exactly match the photovoltaic module with battery.

A 12v lead acid battery is used here to meet the expected requirements. For charging mobiles we need only 5v. A DC-DC converter is used for this purpose. The DC-DC converter used here is a buck converter that converts 12v to 5v. In the absence of sun light we provide an additional source like dynamo or energy from an automobile. The energy from the external source is controlled by a charge controller. The MPPT module and the charge

controller is continuously monitored by the microcontroller section. The microcontroller section also perform logical decision making. We use AVR (ATmega 328) microcontroller with modified memory architecture and low power consumption. To charge the lighting system we need to convert dc to ac, for this purpose we use an inverter. It consists of a driver circuitry and a power circuitry. The step-up transformer here acts as a voltage booster. The charging ports can be used to charge the mobile phones and the power socket can be used to power the basic lighting system. In LED panels the LEDs are connected in series which can be used as a secondary lighting system .

B. Componets

1. Solar panel
2. MPPT charge controller
3. Battery
4. DC-DC converter (LM2576)
5. AVR microcontroller (ATmega 328)
6. Inverter (KA3525)
7. Step up transformer
8. LED panels

C. Componets specification

a) Microcontroller section (ATmega 328)

The ATmega 328 is a single chip microcontroller created by Atmel in the AVR family. It is considered as a third generation microcontroller. Here the microcontroller continuously monitor the charge and perform logical decision making. It is 8 bit microcontroller with 28 pins.

Specifications and features

- Operating voltage = 1.8 – 5.5V
- Maximum operating frequency = 20MHz
- Three types of memory (32K of flash memory, 1K of EEPROM AND 2K of internal SRAM)
- General purpose I/O pins= 23
- Timers (two 8 bit timer TC0&TC2) and one 16 bi timer TC1)
- Real time clock
- ADC (successive approximation type)
- Serial communication devices(USART, SPI and TWI)
- Analog comparator
- Power supervision section
- Watch dog timer with separate on chip oscillator.

Pin out

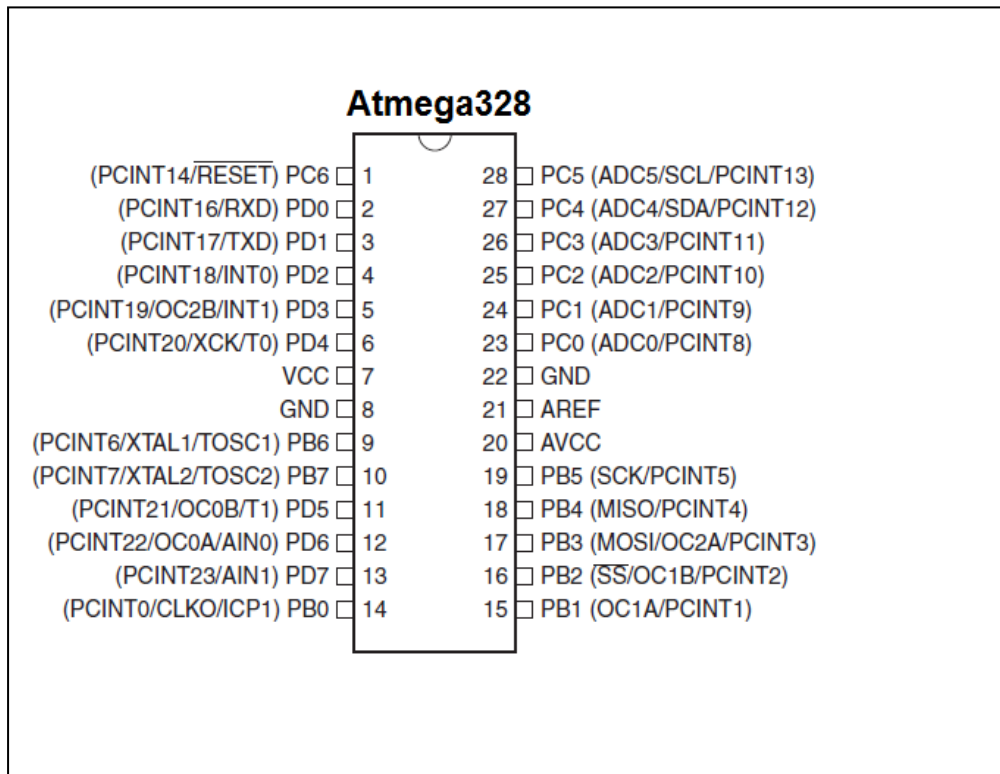

Figure 2: pin out of ATmega 328

Pin description

- GND
- VCC : digital power supply
- Port B (PB7:PB0)
8 bit bi-directional I/O port. Pins are externally pulled low will source current if the pull up resistor are activated current tri-stated even in the reset condition and if the clock is not running.
PB6- input to the inverting oscillator amplifier and input to the inverting clock operating circuit.
PB7- output from the inverting oscillator amplifier.
PB6:7- input for asynchronous timer
- Port C (PC5:PC0) -7 bit bidirectional I/O port.
- Port D (PD7:PD0) – 8 bit bidirectional I/O port.
- RESET - a low level on this pin for longer than the minimum pulse length will generate.
- AVCC – supply voltage pin for A/D converter.
- AREF – Analog reference pin for A/D converter.
- ADC 7:6- Analog input to the A/D converter.
- PCINT pins- port change interrupt.

b) DC-DC converter section (LM2576)

DC-DC converter is chosen over voltage regulator and zener voltage regulators as efficiency of both of them are less than 60% and their input voltage levels are limited. Whereas efficiency of DC-DC converter is above 80%, so we use LM2576 which meets our requirements of 1A or 2A supply.

Specifications and features

[NACETEC' 19]
 IC™ Value: 3.00

- 3.3V, 5V, 12V, 15V and adjustable output versions.
- 3A output current.
- Maximum supply voltage 40-45V.
- Wide input voltage range.
- 53KHz fixed frequency internal oscillator.
- Inbuilt thermal shutdown and current limit protection.
- Output voltage for fixed voltage regulator- 3.3V, 5V, 12V, 15V.
- Output voltage for variable voltage regulator – 1.23V-37V.

Pin out

Straight Leads 5-Lead TO-220 (T) Top View

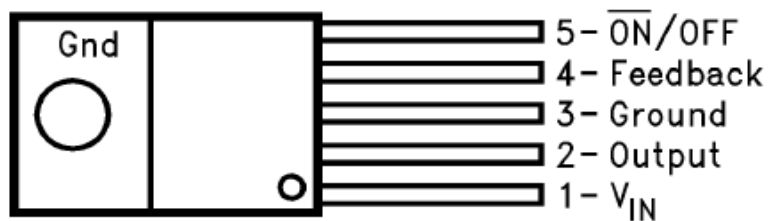

Figure: 3 pin out of LM2576

Pin description

- VIN – the voltage which has to be regulated is provided as input to this pin.
- OUTPUT – The regulated output can be obtained.
- GND.
- FEEDBACK- this pin is provided with the feedback voltage based on which the output is regulated.
- ON/OFF – connect to ground to activate regulated or connect to VCC to disable the regulator.

c) LED panel

We use white LEDs. For proper working it requires 3-3.3V. series of LEDs are used based on the requirement.

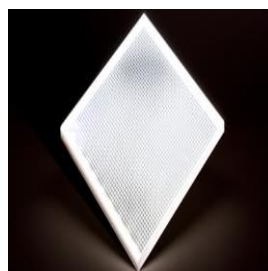

d) Inverter (KA3525)

It maintains the oscillation of the PWM and enhances the power. It has an error amplifier .it is used to adjust the duty cycle of the PWM.

Specifications

http:// www.ijesrt.com © International Journal of Engineering Sciences & Research Technology

[223]



- Supply voltage – 8V-35V
- Frequency- 100-400Hz
- Reference voltage- 5.1V

Pin out

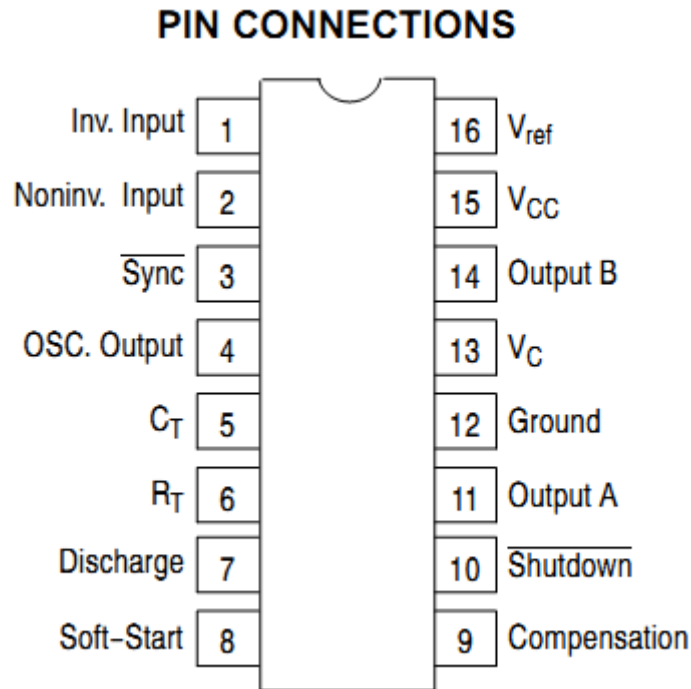

Figure 4: pin out of KA3525

e) Solar panel

The solar panel absorb sunlight as a source of energy to generate electricity. A large number of solar cell make solar modules and a number of solar modules make a solar panel. The conversion of solar energy in to electricity is by the solar photovoltaic effect. Each module is typically range from 100 to 320w.



Figure 5: solar panel

f) Power supply section (linear voltage regulator)

Voltage source in circuits may have fluctuations; as a result we will not get a fixed voltage output. A regulated power supply is essential for several electronic devices due to the semiconductor material employed in them have fixed rate of current as well as voltage. The device may get damaged if there is any fluctuation. 7805 IC is a member of 78xx series of fixed voltage regulator used to maintain such fluctuations. The xx in 78xx indicates the maximum output voltage it can provide. In 7805 IC it can provide +5 regulated power supplies.

Pinout diagram

[http:// www.ijesrt.com](http://www.ijesrt.com) © International Journal of Engineering Sciences & Research Technology

[224]



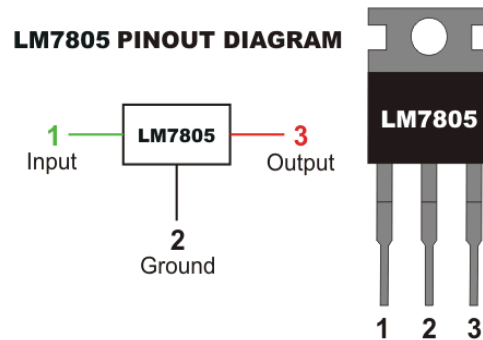

Figure 6: pinout diagram of LM7805

Pin description

1. Input – input voltage is within the range of 7V-35V. The unregulated voltage is given to this pin for regulation.
2. Ground
3. Output – the regulated 5V is taken out from this pin.

g) MOSFET driver IC in MPPT (IR2104)

Pinout

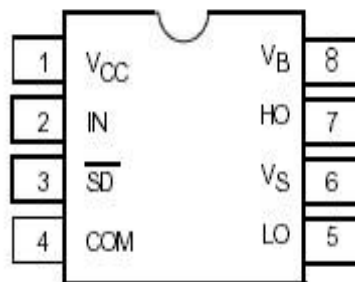

Figure 7: pinout of ir2104

Pin description

1. VCC- low side and logic fixed supply.
2. IN – logic input for high and low side gate driver outputs.
3. SD- logic input for shutdown.
4. COM – low side return.
5. LO – low side gate driver output.
6. VS – High side floating supply return.
7. HO- high side gate drive output.
8. VB- high side floating supply

5. ADVANTAGES OF PROPOSED SYSTEM

- Highly efficient and sustainable over diesel and gasoline powered generators.
- Can deploy and redeploy as per requirements.
- Self sufficient, reliable, secure and noise free.
- Highly mobile.
- Uses renewable energy tapping mechanism.

6. CONCLUSION AND FUTURE WORK

[NACETEC' 19]

ICTTM Value: 3.00

In response to disasters, solar based emergency power solutions can offer a source of safe, quiet and pollution free electrical power. It is capable of providing electrical needs for lighting, medical equipments, charging phones, fans and other general electrical needs. It can act as a viable source of electrical power for relief camp applications such as low power needs and long term use. As they are designed specifically for stand-alone operations where utility power is unavailable, it stands as a natural solution during disasters. The scope of the project extends to provide electricity to remote areas that have no access to grid.

As a future work, the project can be extended with further development such as introducing remote sensors for disaster monitoring, which provides real time monitoring and analysis of disaster risks. Solar driven water purifiers can also be added along as availability of clean water is of major concern during disasters. An embedded GSM approach can also be implemented for communication purposes.

REFERENCES

- [1] Soteris A. Kalogirou Solar Energy Engineering Elsevier 2009
- [2] R.S.L. Das S. Krauthamer A. Bulawka "High performance low cost power conditioning subsystems using smart power/power integrated circuits in photovoltaic power systems". Proceeding of: Energy Conversion Engineering Conference 1996. IECEC 96. 11-16 Aug 1996 Washington DC USA pp. 1685-1690 vol.3.
- [3] N. Femia G. Petrone G. Spagnuolo M. Vitelli "Optimization of perturb and observe maximum power point tracking method" IEEE Transactions on Power Electronics Volume 20 Issue 4 July 2005 pp 963 - 973
- [4] M.A. Green "Solar Cells: Operating Principles Technology and System Applications" Prentice-Hall NJ 1982 ISBN 0858235803.
- [5] K. H. Hussein, I. Muta, T. Hshino, and M. Osakada, "Maximum photovoltaic power tracking: an algorithm for rapidly changing atmospheric conditions," Proc. Inst. Elect. Eng., vol. 142, no. 1, pp. 59–64, Jan. 1995